



CME-550X

- Cummins diesel 120 horsepower engine powers both drill and carrier
- High torque drill spindle rating of 11,245 ft/lbs
- High speed drill spindle option rated at 900 rpm
- CME patented safety shutdown systems and optional back-up camera
- MWD, CPT, SPT and probe hammer options available
- Multiple hoist and water pump options available
- CME designed and built carrier offers 4x2 and 4x4 modes
- Carrier ground speed up to 17 mph
- Auger rack, drill rod rack, and tool boxes built into the carrier

CENTRAL MINE EQUIPMENT COMPANY
800-325-8827 • info@cmeco.com • www.cmeco.com



CME-550X



Power

Cummins QSF 3.8 (229 cubic inch) 120 horsepower Tier-4f
4-cylinder turbocharged, diesel engine

Carrier

Tire size:

Front: 46 inch diameter x 23.6 inch wide

Rear: 46 inch diameter x 28 inch wide

Ground bearing pressure: (without tools) 9 psi

Transmission: 5 speed forward, 1 speed reverse

Axles planetary with no-spin differentials and wheel end brakes

Air-shift transfer case for 4x2 or 4x4 mode

Steering: hydraulic power

Hydraulic front winch, standard: 12,000 pound (5,443 kg)
optional: 20,000 pound (9,071 kg)

Body

Underbody auger rack, helper side

Underbody tool box, driller side

Water tank, 160 gallon (605 liter) capacity

Front end auger rack

Tool boxes on deck, both sides

Rod rack on deck, helper side

Leveling system

Three hydraulic jacks, 36 inch (91.4 cm) stroke

Hydraulic Feed System

Retract force.....28,275 pounds (12,825 Kg)

Pulldown force.....18,650 pounds (8,460 Kg)

Retract rate.....35 feet (10.7 m) per minute

Rapid retract rate.....90 feet (27.4 m) per minute

Feed rate.....55 feet (16.8 m) per minute

Stroke.....72 inch (183 cm)

Rotary Drive

Clutch, heavy duty.....14 inch (35.6 cm)

Transmission.....5 speed forward, 1 speed reverse

Rotary torque, standard.....9,000 foot pounds (12,202 Nm)

Rotary speed, standard.....up to 765 rpm

Rotary torque, high speed....7,670 foot pounds (10,399 Nm)

Rotary speed, high speed.....up to 900 rpm

Rotary torque, high torque..11,245 foot pounds (15,246 Nm)

Rotary speed, high torque.....up to 615 rpm

Hollow spindle I.D., standard.....2.75 inch (7 cm)

optional.....3.75 inch (9.5 cm)

Available Options

Water Pump Options

Moyno 3L6 - 36 gpm/225 psi (136 lpm/1,551 kPa)

Moyno 3L8 - 84 gpm/225 psi (318 lpm/1,551 kPa)

Bredel hose pumps

Bean L09 (420) - 25 gpm/500 psi (95 lpm/3,448 kPa)

Bean L1122 (435) - 35 gpm/500 psi (132 lpm/3,448 kPa)

Hoist Options

1,800 pound (816 kg)

3,200 pound (1,452 kg)

7,000 pound (3,175 kg)

8,500 pound (3,855 kg)

Hydraulic wireline hoists

Hydraulic Rod Holder and Break-out Wrench Options

4 1/2 inch (11.4 cm) capacity

5 1/2 inch (14 cm) capacity

6 5/8 inch (16.8 cm) capacity

Fixed or adjustable height

CME Automatic Hammer System Options

110 pound (49.9 kg)

140 pound (63.5 kg)

170 pound (77.1 kg)

300 pound (136.1 kg)

340 pound (154.2 kg)

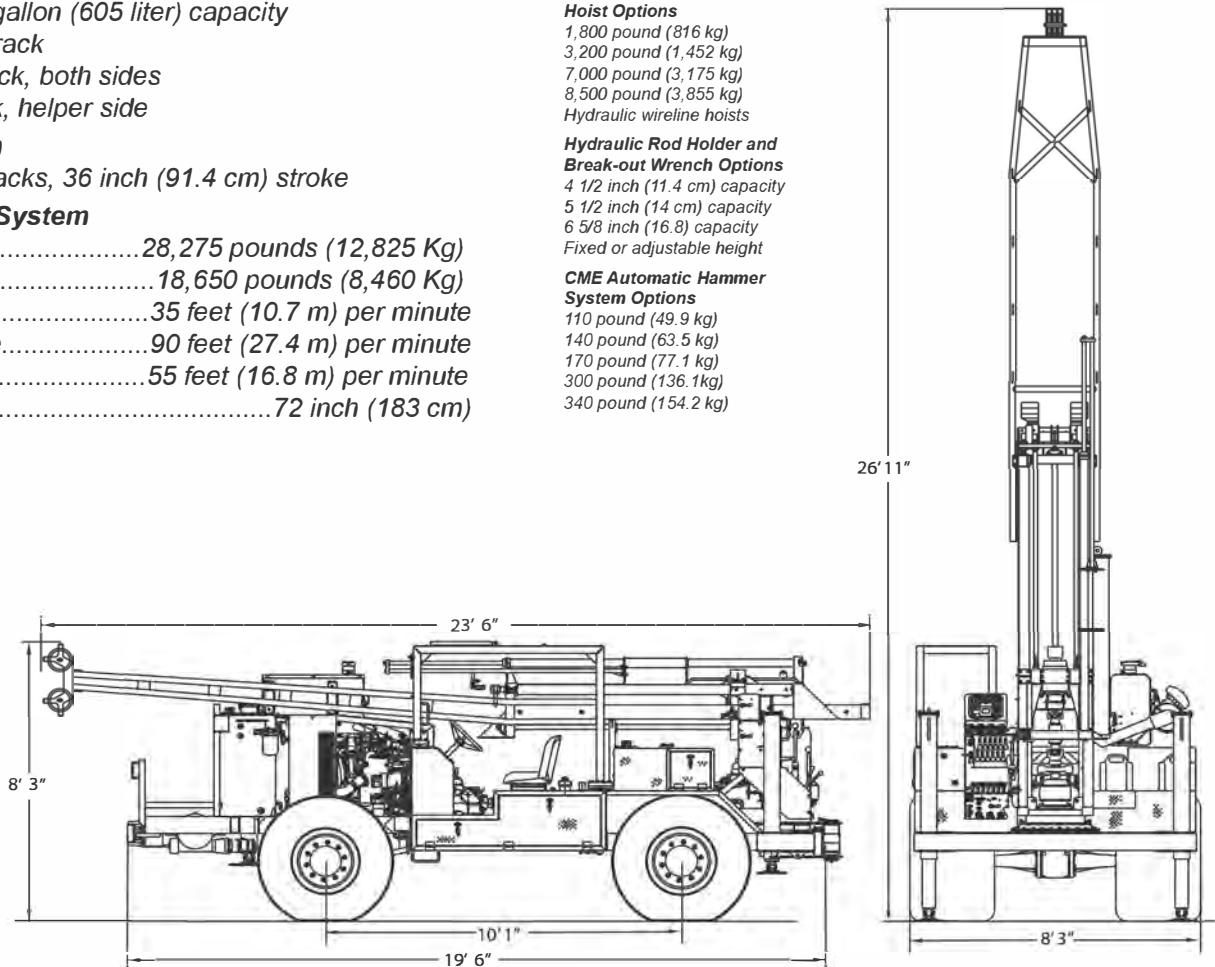

CENTRAL MINE EQUIPMENT COMPANY

4215 Rider Trail North, Earth City (St. Louis), Missouri, 63045 USA

Phone: 314-291-7700 1-800-325-8827

E-mail: info@cmeco.com Website: www.cmeco.com

Performance ratings are based on engineering specifications, calculations and accepted industry standards. Capacities may vary according to drilling conditions.

CME reserves the right to amend these specifications at any time, without notice.

MKT 550X 100 2/2023 Printed in USA

© Central Mine Equipment Company 2023